

PRODUCT DATA SHEET

SFP Media Converter 1.25Gbps MM 2 Fibers (LC)

Feature:

- SFP package with LC connector
- 850nm VCSEL Laser and PIN photo detector
- Up to 550m transmission on 50/125 um MMF
- +3.3V single power supply
- LVPECL compatible data input/output interface
- Low EMI and excellent ESD protection
- laser safety standard IEC-60825 compliant
- Compatible with RoHS
- Digital Diagnostic SFF-8472 compliant



Application :

- 1.25 Gb/s 1000Base-SX Ethernet
- Dual Rate 1.063/2.125 Gb/s Fibre Channel
- Wireless – CPRI, OBSAI, LTE

Absolute Maximum Ratings:

Parameter	Symbol	Minimum	Maximum	Units
Storage Temperature	Tst	-40	+85	°C
Supply Voltage	Vcc	-0.3	+4.0	V
Operating Relative Humidity	RH	5	95	%

Operation Environment:

Parameter	Symbol	Min	Typical	Max	Units
Supply Voltage	Vcc	3.15		3.45	V
Operating Case Temperature	Tc	0		+70	°C
Power Dissipation				1	W
Data Rate			1250		Mbps



Optical Characteristics:

(Ambient Operating Temperature 0°C to +70°C, Vcc =3.3 V)

Parameter	Symbol	Min.	Typ.	Max.	Units
Transmitter Section					
Center Wavelength	λ_o	830	850	860	nm
Average Output Power	Po	-9	-	-3	dBm
Extinction Ratio	Er	8	-		dB
Rise/Fall Time(20%~80%)	Tr/Tf			150	ps
Total Jitter	Tj			0.43	UI
Optical Eye Diagram	IEEE 802.3z and ANSI Fibre Channel Compatible				
Receiver Section					
Center Wavelength	λ_o	830		860	nm
Receiver Sensitivity	Rsen			-19	dBm
Receiver Overload	Rov	-3			dBm
Return Loss		12			dB
LOS Assert	LOSA	-36			dBm
LOS Dessert	LOSD			-20	dBm
LOS Hysteresis		0.5		5	

Electrical Characteristics:

(Ambient Operating Temperature 0°C to +70°C, Vcc =3.3 V)

Parameter	Symbol	Min.	Typ.	Max.	Unit
Transmitter Section					
Input Differential Impedence	Zin	90	100	110	Ohm
Data Input Swing Differential	Vin	500		2400	mV
TX Disable	Disable	2.0		Vcc	V
	Enable	0		0.8	V
TX Fault	Assert	2.0		Vcc	V
	Deassert	0		0.8	V
Receiver Section					
Output Differential Impedence	Zout		100		Ohm
Data Input Swing Differential	Vout	370		2000	mV
Rx_LOS	Assert	2.0		Vcc	V
	Deassert	0		0.8	V

EEPROM Information (A0)

Addr	Field Size (Bytes)	Name of Field	HEX	Description
0	1	Identifier	03	SFP
1	1	Ext. Identifier	04	MOD4
2	1	Connector	07	LC
3-10	8	Transceiver	00 00 00 02 12 00 0D 01	Transmitter Code
11	1	Encoding	01	8B10B
12	1	BR, nominal	0D	1250M bps
13	1	Reserved	00	
14	1	Length (9um)-km	00	
15	1	Length (9um)	00	
16	1	Length (50um)	37	550m
17	1	Length (62.5um)	1B	270m
18	1	Length (copper)	00	
19	1	Reserved	00	
20-35	16	Vendor name	57 49 4E 54 4F 50 20 20 20 20 20 20 20 20 20 20	Nitrotel
36	1	Reserved	00	
37-39	3	Vendor OUI	00 00 00	
40-55	16	Vendor PN	xx xx xx xx xx xx xx xx xx xx xx xx xx xx xx xx	ASC II
56-59	4	Vendor rev	31 2E 30 20	V1.0
60-61	2	Wavelength	03 52	850nm
62	1	Reserved	00	
63	1	CC BASE	XX	Check sum of byte 0~62
64-65	2	Options	00 1A	LOS, TX_DISABLE, TX_FAULT
66	1	BR, max	32	50%
67	1	BR, min	32	50%
68-83	16	Vendor SN	00 00 00 00 00 00 00 00 00 00 00 00 00 00 00 00	Unspecified
84-91	8	Vendor date code	XX XX XX 20	Year, Month, Day
92-94	3	Reserved	00	
95	1	CC_EXT	XX	Check sum of byte 64~94
96-255	160	Vendor specific		

Pins	Name	Description	Note
1	VeeT	Transmitter Ground	
2	Tx Fault	Transmitter Fault Indication	1
3	Tx Disable	Transmitter Disable	2
4	MOD DEF2	Module Definition 2	3
5	MOD DEF1	Module Definition 1	3
6	MOD DEF0	Module Definition 0	3
7	RS0	Not Connected	
8	LOS	Loss of Signal	4
9	RS1	Not Connected	
10	VeeR	Receiver Ground	
11	VeeR	Receiver Ground	
12	RD-	Inv. Received Data Output	5
13	RD+	IReceived Data Output	5
14	VeeR	Receiver Ground	
15	VccR	Receiver Power	
16	VccT	Transmitter Power	
17	VeeT	Transmitter Ground	
18	TD+	Transmit Data Input	6
19	TD-	Inv. Transmit Data Input	6
20	VeeT	Transmitter Ground	

Notes:

1. TX Fault is an open collector output, which should be pulled up with a 4.7k~10kΩ resistor on the host board to a voltage between 2.0V and Vcc+0.3V. Logic 0 indicates normal operation, logic 1 indicates a laser fault of some kind. In the low state, the output will be pulled to less than 0.8V.
2. TX Disable is an input that is used to shut down the transmitter optical output. It is pulled up within the module with a 4.7k~10kΩ resistor. Its states are:
Low (0~0.8V): Transmitter on
(>0.8V, <2.0V): Undefined
High (2.0~3.3V): Transmitter Disabled
Open: Transmitter Disabled
3. MOD-DEF 0,1,2 are the module definition pins. They should be pulled up with a 4.7k~10kΩ resistor on the host board. The pull-up voltage shall be VccT or VccR.
MOD-DEF 0 is grounded by the module to indicate that the module is present
MOD-DEF 1 is the clock line of two wire serial interface for serial ID
MOD-DEF 2 is the data line of two wire serial interface for serial ID
4. LOS is an open collector output, which should be pulled up with a 4.7k~10kΩ resistor on the host board to a voltage between 2.0V and Vcc+0.3V. Logic 0 indicates normal operation; logic 1 indicates loss of signal. In the low state, the output will be pulled to less than 0.8V.
5. These are the differential receiver output. They are internally AC-coupled 100Ω differential lines which should be terminated with 100Ω (differential) at the user SERDES.
6. These are the differential transmitter inputs. They are AC-coupled, differential lines with 100Ω differential termination inside the module.



Recommended Application Circuit:

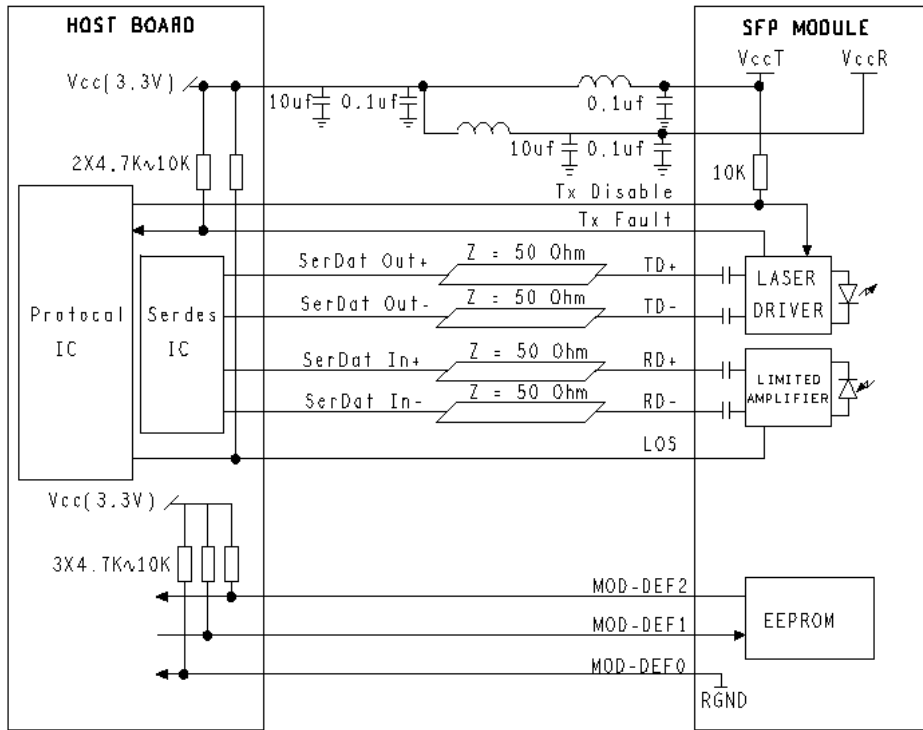

Outline Dimension (mm)

